

Milling · Fräsen

Indexable Milling Tools · Wendepplattenfräser

High feed milling cutters · Hochvorschubfräser

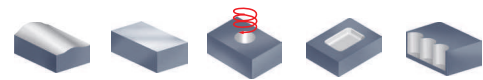

XMR01 P M K



S type insert, straight shank
S Typ WSP, Zylinder Schaft

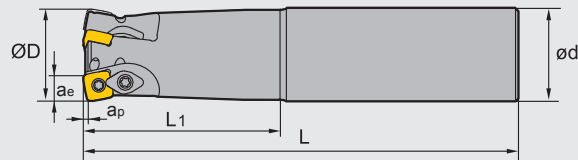

■ Specification of tools · Werkzeug Beschreibung with Internal Cooling · Mit Innenkühlung

Type · Typ	Stock Lager	Dimensions (mm) · Abmessungen							No. of teeth Zähne	Weight Gewicht (kg)
		Ø D	ap	ae	L1	L	Ø d			
XMR01 -025-G25-SD09-02	●	25	1.4	8.8	60	140	25	2	0.5	
-032-G32-SD09-03	●	32	1.4	8.8	70	150	32	3	0.8	
-035-G32-SD09-03	○	35	1.4	8.8	70	150	32	3	0.8	
-032-G32-SD12-02	●	32	1.8	11.7	70	150	32	2	0.8	
-040-G40-SD12-03	●	40	1.8	11.7	70	150	40	3	1.3	

XMR01 P M K

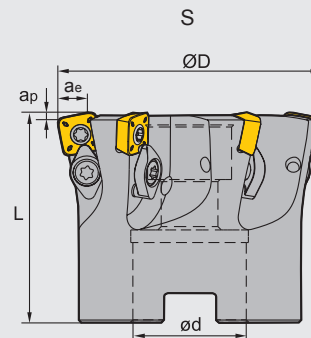

■ Specification of tools · Werkzeug Beschreibung with Internal Cooling · mit Innenkühlung

Type · Typ	Stock Lager	Dimensions (mm) · Abmessungen						No. of teeth Zähne	Coupling Aufnahme	Weight Gewicht (kg)
		Ø D	ap	ae	L	Ø d				
XMR01 -050-A22-SD09-04	●	50	1.4	8.8	40	22	4	A	0.3	
-063-A22-SD09-06	●	63	1.4	8.8	40	22	6	A	0.5	
-063-A27-SD09-06	○	63	1.4	8.8	50	27	6	A	0.6	
-063-A22-SD12-05	●	63	1.8	11.7	40	22	5	A	0.5	
-063-A27-SD12-05	○	63	1.8	11.7	50	27	5	A	0.6	
-080-A27-SD12-05	●	80	1.8	11.7	63	27	5	A	0.9	
-100-B32-SD12-06	●	100	1.8	11.7	50	32	6	B	1.8	

● Ex Stock / ab Lager ○ On demand / auf Anfrage

Spare parts · Ersatzteile

Tool Werkzeug	Insert Screw Schraube	Clamp Screw Schraube	Clamp Pratze	Wrench Schlüssel	
	XMR01**-SD09**	I60M3.5×08TT	I60M4×8.4	WD-204	WT10IP
XMR01**-SD12**	I60M4×8.4		WT15IP		

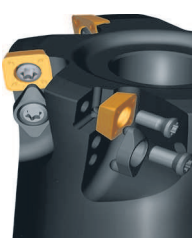

Applicable inserts · Wendeschneidplatten

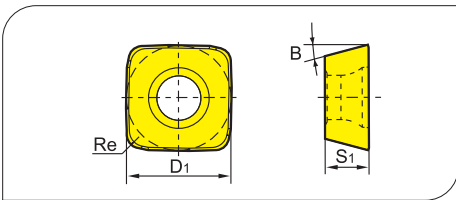

- Ideal Machining Condition / Gute Bearbeitungsbedingungen
- Normal Machining Condition / Normale Bearbeitungsbedingungen
- Unfavorable Machining Condition / Ungünstige Bearbeitungsbedingungen

Workpiece Material Werkstoffe	P	M	K	N	S	Steel / Stahl	Stainless Steel / Rostfreier Stahl	Cast iron / Gusseisen	Non-ferrite material / Ne Metalle	Heat-resistant steel / Warmfester Stahl
P	●	●	●	●	●	●	●	●	●	●
M	●	●	●	●	●	●	●	●	●	●
K			●	●	●			●	●	●
N									●	●
S										●

Insert WSP	Type · Typ	Dimensions (mm) · Abmessungen				CVD Coating CVD Beschicht.				PVD Coating PVD Beschicht.				Cermet		Carbide uncoat. unbe. Hartmetall								
		B	Re	S1	D1	YBC301	YBC401	YBM251	YBM351	YBD152	YBD252	YBG102	YBG202	YBG205	YBG302	YBG152	YBG252	YNG151	YNG151C	YC30S	YD051	YD101	YD201	
	SDMT09T312-DM	15°	1.2	3.97	9.525				●	○		●	○											
	SDMT120412-DM	15°	2.0	4.76	12.7				●	○		●	○											

Applicable tool **B9-B15**
Werkzeug

Tools code key **B22-B23**
Werkzeug ISO

Grade selection guide **B16-B20**
Sortenauswahl

Technical data **B183-B188**
Technische Daten