

i-Xmill BALL HOLDERS - STEEL

i-Xmill HALTER für WECHSELPLATTE mit RUNDER STIRN - STÄHLE

- ▶ Premium alloy steel with excellent strength.
- ▶ Precise shank, Tolerance (h6).
- ▶ Nickel plated, to prevent corrosion and improve lubricity.

- ▶ Premium legierter Stähle mit großer Festigkeit.
- ▶ Hochgenauer Schaft, Tol h6.
- ▶ Vernickelt, verhindert Korrosion und verbessert die Schmierfähigkeit.

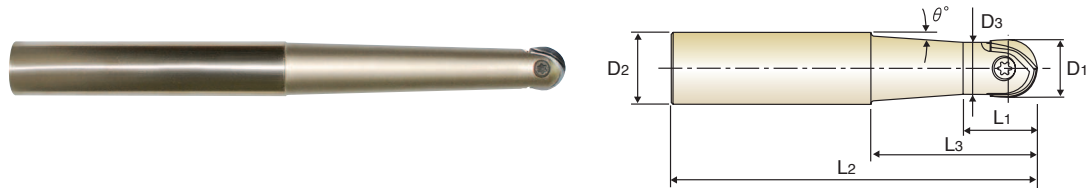

TAPER NECK TYPE

Unit : mm

EDP No.	Mill Diameter	Shank Diameter	Length of Cut	Length Below Shank	Overall Length	Neck Diameter	Taper Angle	Length Type	Wrench No.	Screw No.
	D1	D2	L1	L3	L2	D3	θ°			
ZBT0801120	8.0	12	12	35	90	7.2	4° 43'	Short	TWFT07	TX2508T07
ZBT0802120			25	55	110		3° 37'	Regular		
ZBT1001120	10.0	12	15	35	90	9	2° 51'	Short	TWFT08	TX3010T08
ZBT1002120			30	55	110		2° 17'	Regular		
ZBT1201160	12.0	16	17	55	110	10.5	3° 23'	Short	TWFT10	TX3512T10
ZBT1601200	16.0	20	20	65	125	14.5	2° 51'	Short	TWFT15	TX4016T15
ZBT2001250	20.0	25	25	75	145	18	3° 26'	Short	● TWBT20	TX5020T20
ZBT2501320	25.0	32	30	90	170	22.5	4° 03'	Short	● TWBT25	TX6025T25
ZBT3001320	30.0 32.0	32	40	110	195	27	1° 38'	Short	● TWBT30	TX8030T30

● Required to use T-HANDLE (TWH600)



STRAIGHT NECK TYPE

Unit : mm

EDP No.	Mill Diameter	Shank Diameter	Length Below Shank	Overall Length	Neck Diameter	Length Type	Wrench No.	Screw No.
	D1	D2	L3	L2	D3			
ZBS1201120	12.0	12	35	90	10.5	Short	TWFT10	TX3512T10
ZBS1202120			55	110		Regular		
ZBS1601160	16.0	16	35	95	14.5	Short	TWFT15	TX4016T15
ZBS1602160			65	125		Regular		
ZBS2001200	20.0	20	40	110	18	Short	● TWBT20	TX5020T20
ZBS2002200			75	145		Regular		
ZBS2501250	25.0	25	45	125	22.5	Short	● TWBT25	TX6025T25
ZBS2502250			90	170		Regular		
ZBS3001320	30.0, 32.0	32	55	140	27	Short	● TWBT30	TX8030T30
ZBS3002320			110	195		Regular		

● Required to use T-HANDLE (TWH600)

**ASSEMBLY OF *i-Xmill*
MONTAGE DES *i-Xmill***

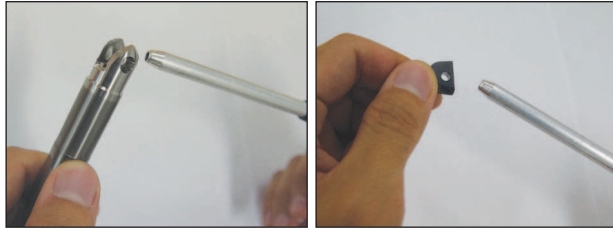

◀ Make sure to clean the insert and insert seat.
Wechselplatte und Plattensitz sorgfältig reinigen.

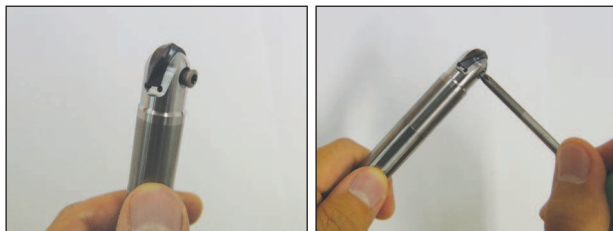

◀ Slide the insert into the slot of the holder.
Tighten the screw using anti-seize compound.
Wechselplatte in den Sitz des Halters einführen.
Die Schraube fest anziehen und dabei Spezialfett verwenden

SIZE (ØD)	CLAMPING TORQUE [N · m]
Ø8	1.0
Ø10	1.5
Ø12, Ø13	2.5
Ø16, Ø17	3.5
Ø20, Ø21	5.0
Ø25, Ø26	6.0
Ø30, Ø32	6.5

- * When the screw is worn out, please change the new screw.
- * Wenn das Schraubengewinde verschlissen ist, bitte neue Schraube verwenden.
- * Please tighten up the screw with recommended torque. (Please refer to the table)
- * Die Feststellschraube mit dem empfohlenen Anzugsmoment anziehen (siehe Tabelle).
- * Don't press down the insert, when the screw is tightened.
- * Die Wechselplatte nicht nach unten drücken, wenn die Schraube angezogen ist.

CLAMPING DIRECTION

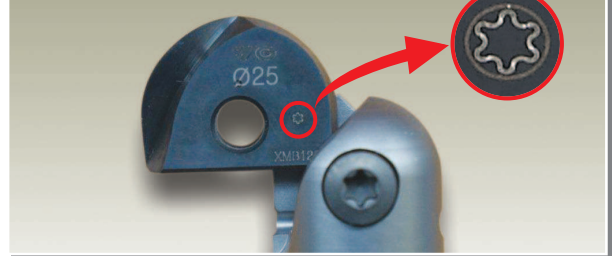

CUTTING CONDITION

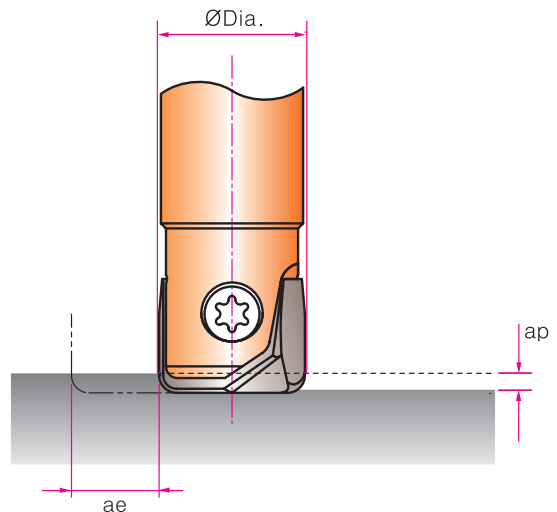
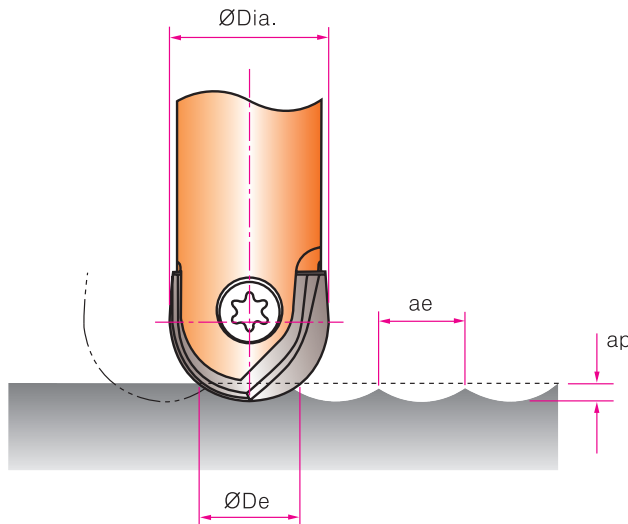

RPM = revolution per minute (rev/min)
Vc = surface meter per minute (M/min)
Dia. = diameter of insert (mm)
Vf = feed speed (mm/min)
f = feed per revolution (mm/rev)
De = effective tool diameter (mm)
ap = axial depth of cut (mm)
ae = radial depth of cut (mm)

$$Vc [M/min] = \frac{(RPM) \cdot (\pi) \cdot (Dia.)}{1000}$$

$$Vf [mm/min] = (RPM) \cdot (f)$$

$$RPM [rev/min] = \frac{(Vc) \cdot (1000)}{(\pi) \cdot (Dia.)}$$

$$De [mm] = 2 \sqrt{(ap) \cdot (Dia. - ap)}$$