

HCHT / HCHF

2-Jaw, 4-Jaw Open-Center Chuck



HYDRAULIC CHUCK

- 2-jaw wedge-style open-center power chuck
- 4-jaw wedge-style open-center power chuck

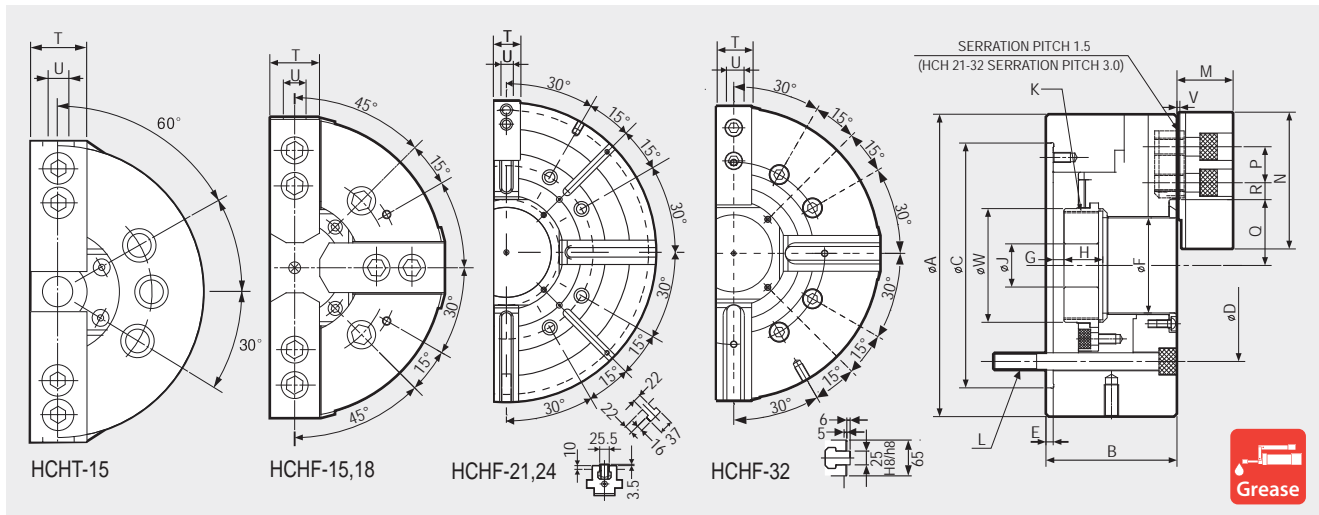

It is recommended to grease chucks at least twice a day in order to maximize longevity.

Dimensions

	A	B	C(H6)	D	E	F	Gmax.	Gmin.	H	I	J	Kmax.	L	M	N	P	Qmax.	Qmin.	Rmax.	Rmin.	T	U	V	W
HCHT-15	381	133	300	235	6	117.5	11	-12	39	30	60	M130x2.0	6-M20	70	165	43	82	76.7	43.75	18.25	62	22	5	139
HCHF-15	381	133	300	235	6	118	11	-12	39	-	60	M130x2.0	4-M20x150	70	165	43	82	76.7	43.75	18.25	62	22	5	139
HCHF-18	450	133	380	235	6	118	11	-12	39	-	60	M130x2.0	4-M20x130	70	165	43	82	76.7	78.25	18.25	62	22	5	136
HCHF-21	530	140	380	330.2	6	140	11	-12	39	-	80	M155x3.0	8-M22x140	72	180	60	98.5	93.2	87.5	21.5	65	25	5	170
HCHF-21N	530	140	380	330.2	6	140	11	-12	39	-	80	M155x3.0	8-M24x140	72	180	60	98.5	93.2	87.5	21.5	65	25	5	170
HCHF-24	610	149	380	330.2	6	165	20	-3	40	-	80	M175x3.0	8-M22x150	72	180	60	102.7	108	117.5	21.5	65	25	5	187
HCHF-24N	610	149	380	330.2	6	165	20	-3	40	-	80	M175x3.0	8-M24x150	72	180	60	102.7	108	117.5	21.5	65	25	5	187
HCHF-32	800	150	520	463.6	6	240	34	0	34.5	-	80	M250x3.0	8-M24x130	83	160	38	162.6	153.6	182	20	75	25.5	3.5	260

* Blank and machined draw-nuts are available.

* "K" is Max. Draw nut size.

Specifications

	Thru Hole Diameter.(mm)	Grip Dia. (mm)		Jaw STROKE Diameter. (mm)	PLUNGER STROKE (mm)	Permissible Input Force KN(kgf)	Max. Static Gripping Force KN(kgf)	Max. r.p.m min~(r.p.m)	weight kgf	GD ² N·m ² (kgf·m ²)	Operating Cylinder	Max. Hydraulic Pressure MPa(kgf/cm ²)	Operating HARD JAW	KITAGAWA [®] Model
		Max.	Min.											
HCHT-15	117.5	381	30	10.6	23	47(4793)	120(12236)	2500	115	87.28(8.90)	SH-25011	1.5(15.3)	-	BT-15
HCHF-15	117.5	381	30	10.6	23	47(4793)	120(12236)	2500	115	87.3(8.90)	SH-25011	1.5(15.3)	HB15A1	-
HCHF-18	117.5	450	30	10.6	23	47(4793)	120(12236)	2000	159	165.8(16.9)	SH-25011	1.5(15.3)	HB15A1	-
HCHF-21	140	530	87	10.6	23	60(6117)	156(15907)	1700	235	351.2(35.8)	SH-25011	1.97(20.1)	HB18B2	-
HCHF-21N	140	530	87	10.6	23	60(6117)	156(15907)	1700	235	351.2(35.8)	SH-25011	1.97(20.1)	HB18B2	-
HCHF-24	165	610	110	1.06	23	60(6117)	156(15907)	1400	293	651.4(66.4)	SH-25011	1.97(20.1)	HB18B2	-
HCHF-24N	165	610	110	10.6	23	60(6117)	156(15907)	1400	293	651.4(66.4)	SH-25011	1.97(20.1)	HB18B2	-
HCHF-32	240	800	160	18	34	60(6795)	156(15821)	11200	530	601(61)	SYHL-2816	2.2(22.4)	HB32B2	-

* Maximum Turning Speed is based on actual measurements.

* Specifications are subject to change without notice.

* Samcully Machinery Co., Ltd. is no longer an OEM manufacturer for Kitagawa[®] Iron Works Co., Ltd.