

## ROUGH HEADS 90° APPROACH

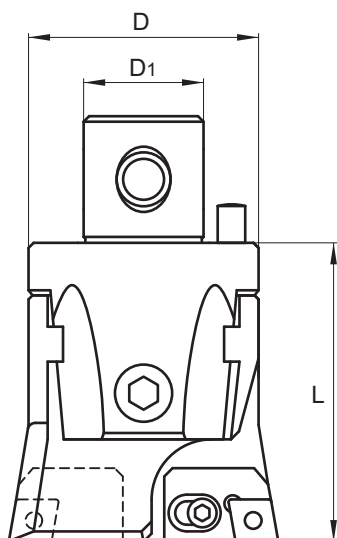

### CARTRIDGE TYPE HEADS SYNCHRONIZED ADJUSTMENT

Bore Range		Dimension			Product Number	Cartridge *	Clamp Screw	Kg.	Adjustment		
Min	Max	øD	øD1	L					Adj. Key	Clamp Key	Locking Key
80	102	68	36	86	<b>D68 90 300</b>	2CT 90 300	TT 409	2.300	4	T15	8
80	102	68	36	86	<b>D68 90 402</b>	2CT 90 402	TT 402	2.300	4	T20	8
80	102	68	36	86	<b>D68 90 402N</b>	2CT 90 402N	TT 402N	2.300	4	2.5	8
100	125	85	50	100	<b>D85 90 300</b>	3CT 90 300	TT 300	4.300	5	T15	8
100	125	85	50	100	<b>D85 90 402</b>	3CT 90 402	TT 402	4.300	5	T20	8
100	125	85	50	100	<b>D85 90 402N</b>	3CT 90 402N	TT 402N	4.300	5	2.5	8
125	160	110	60	100	<b>D100 90 300</b>	3CT 90 300	TT 300	6.800	5	T15	8
125	160	110	60	100	<b>D100 90 402</b>	3CT 90 402	TT 402	6.800	5	T20	8
125	160	110	60	100	<b>D100 90 402N</b>	3CT 90 402N	TT 402N	6.800	5	2.5	8
160	220	145	60	100	<b>D200 90 300</b>	3CT 90 300	TT 300	9.000	5	T15	8
160	220	145	60	100	<b>D200 90 402</b>	3CT 90 402	TT 402	9.000	5	T20	8
160	220	145	60	100	<b>D200 90 402N</b>	3CT 90 402N	TT 402N	9.000	5	2.5	8

\* FULL CARTRIDGE INFORMATION (INCLUDING INSERT SIZE) IN PAGE 19