

FINISH HEADS 75° APPROACH

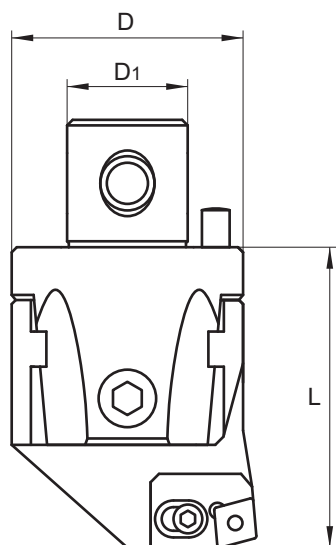

CARTRIDGE TYPE HEADS ADJUSTING ACCURACY 0.002 mm Ø

Bore Range		Dimension			Product Number	Cartridge *	Clamp Screw	Kg.	Adjusting Accuracy		
Min	Max	øD	øD1	L					Adj. Key	Clamp Key	Locking Key
80	102	68	36	86	A68 75 300	2CT 75 300	TT 409	2.175	5	T15	8
80	102	68	36	86	A68 75 402	2CT 75 402	TT 402	2.175	5	T20	8
80	102	68	36	86	A68 75 402N	2CT 75 402N	TT 402N	2.175	5	2.5	8
100	125	85	50	100	A85 75 300	3CT 75 300	TT 300	4.200	6	T15	8
100	125	85	50	100	A85 75 402	3CT 75 402	TT 402	4.200	6	T20	8
100	125	85	50	100	A85 75 402N	3CT 75 402N	TT 402N	4.200	6	2.5	8
125	160	110	60	100	A100 75 300	3CT 75 300	TT 300	6.600	6	T15	8
125	160	110	60	100	A100 75 402	3CT 75 402	TT 402	6.600	6	T20	8
125	160	110	60	100	A100 75 402N	3CT 75 402N	TT 402N	6.600	6	2.5	8
160	220	145	60	100	A200 75 300	3CT 75 300	TT 300	8.960	6	T15	8
160	220	145	60	100	A200 75 402	3CT 75 402	TT 402	8.960	6	T20	8
160	220	145	60	100	A200 75 402N	3CT 75 402N	TT 402N	8.960	6	2.5	8

* FULL CARTRIDGE INFORMATION (INCLUDING INSERT SIZE) IN PAGE 19