

ACCESORIES

REDUCERS

Dimension						Product Number	Kg.	Coupling Screw
øD	øD1	øD2	øD3	L	L1			
27	15	22	12	26	10	R 27 22 36	0.200	22-68
32	20	22	12	30	10	R 32 22 40	0.250	22-68
42	24	22	12	48	10	R 42 22 58	0.350	22-68
54	28	22	12	76	10	R 54 22 86	0.650	22-68
68	36	22	12	90	12	R 68 22 102	1.050	22-68
32	20	27	15	24	10	R 32 27 34	0.250	27-610
42	24	27	15	40	10	R 42 27 50	0.400	27-610
54	28	27	15	70	10	R 54 27 80	0.700	27-610
68	36	27	15	83	12	R 68 27 95	1.050	27-610
42	24	32	20	36	10	R 42 32 46	0.450	32-810
54	28	32	20	66	10	R 54 32 76	0.750	32-810
68	36	32	20	78	12	R 68 32 90	1.200	32-810
54	28	42	24	60	10	R 54 42 70	0.950	42-1014
68	36	42	24	70	12	R 68 42 82	1.400	42-1014
85	50	42	24	83	12	R 85 42 95	2.050	42-1014
68	36	54	28	60	12	R 68 54 72	1.650	54-1220
85	50	54	28	78	12	R 85 54 90	2.500	54-1220
85	50	68	36	88	12	R 85 68 100	3.350	68-1624
100	60	85	50	88	12	R 100 85 100	5.600	85-1630

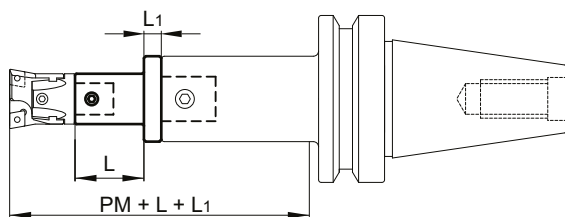
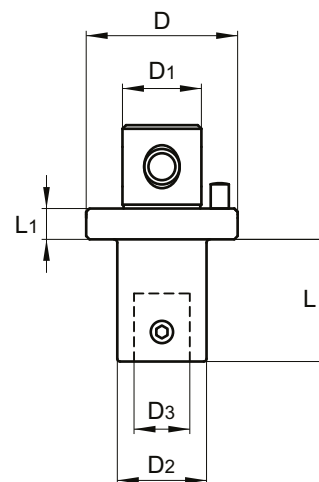

45° CHAMFERING HEADS

Dimension			Product Number	Insert	Clamp Screw	Kg.	Key	
øD	øD1	L					Clamp Key	Locking Key
22	43	24	CH 22	DCMT 11T3..	TT 409	0.100	T15	4
27	48	24	CH 27	DCMT 11T3..	TT 409	0.180	T15	4
32	62	30	CH 32	DCMT 11T3..	TT 409	0.260	T15	5
42	72	30	CH 42	DCMT 11T3..	TT 409	0.330	T15	5
54	94	40	CH 54	DCMT 1504..	TT 402	0.770	T20	6
68	110	40	CH 68	DCMT 1504..	TT 402	1.020	T20	8
85	145	55	CH 85	DCMT 1504..	TT 402	2.340	T20	10
100	170	60	CH 100	DCMT 1504..	TT 402	3.500	T20	14
100	200	60	CH 200	DCMT 1504..	TT 402	5.600	T20	14

