



Gewindeschneid-Schnellwechselfutter mit Längenausgleich auf Druck und Zug

Quick change tapping chucks **with** length compensation on compression and expansion

Mandrins de taraudage à changement rapide **avec** compensation longitudinale à la compression et traction

DIN 69871



Verwendung:

Zur Aufnahme von Schnellwechsel-Einsätzen für Gewindebohrer.

Application:

For the chucking of quick change adaptors for taps.

Application:

Pour le serrage d'adaptateurs porte-tarands à changement rapide.

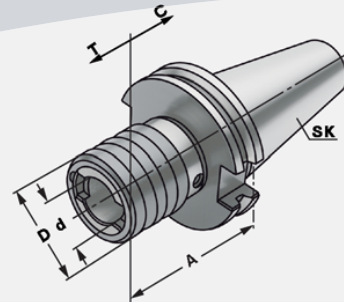

DIN 69871

Form
A

G6,3
15.000 min⁻¹

CAD



Bestell-Nr. Order no. Référence	SK	Spannbereich Capacity Capacité	Größe Size Taille					
				A	D	d	T	C
302.16.12	SK 30	M3 – M14	1	65	38	19	7	7
302.16.20	SK 30	M5 – M22	2	99	54	31	12	12
402.16.12	SK 40	M3 – M14	1	59	38	19	7	7
402.16.20	SK 40	M5 – M22	2	97	54	31	12	12
402.16.36	SK 40	M14 – M36	3	156	78	48	17,5	17,5
502.16.12	SK 50	M3 – M14	1	63	38	19	7	7
502.16.20	SK 50	M5 – M22	2	97	54	31	12	12
502.16.36	SK 50	M14 – M36	3	140	78	48	17,5	17,5

Hinweis:

Für Bearbeitungszentren ohne Synchronspindel.

Note:

For machining centres without synchronous spindle.

Observation:

Pour centres d'usinage sans broche synchrone.



8.67



8.68



8.73



8.61