



Hydro-Dehnspannfutter mit Zylinderschaft

Hydraulic expansion chucks for tool shanks

Mandrins expansibles hydrauliques pour queues cylindriques



Verwendung:

Zur Aufnahme von Werkzeugen mit Zylinderschaft nach DIN 1835 Form A+B+E und DIN 6535 Form HA+HB+HE (größer Ø 20 mm nur mit Reduzierung).

Application:

For mounting straight-shank tools acc. DIN 1835 form A+B+E and DIN 6535 form HA+HB+HE (larger than dia. 20 mm only with reduction sleeve).

Application:

Pour le serrage d'outils avec queue cylindrique suivant DIN 1835 forme A+B+E et DIN 6535 forme HA+HB+HE (à partir de dia. 20 mm seulement avec réduction).

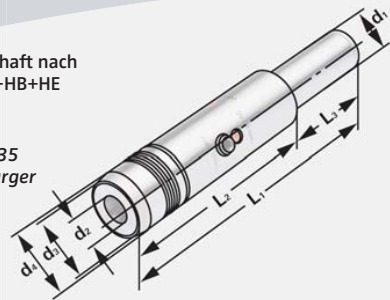

Form A

↗ ≤ 0,003

CAD

Bestell-Nr.
Order no.
Référence

Bestell-Nr. Order no. Référence	d ₁	d ₂	d ₃	d ₄	l ₁	l ₂	l ₃
120.H12.12	12	12	21	25	146	100	46
120.H20.12	20	12	21	25	150	100	50
120.H20.16	20	16	25	28	150	100	50
120.H20.20	20	20	30	32	150	100	50
120.H32.12	32	12	21	25	200	140	60
120.H32.16	32	16	25	28	200	140	60
120.H32.20	32	20	30	32	200	140	60

Lieferumfang: Mit Spanschlüssel
Delivery: With wrench
Livraison: Avec clé de serrage

