



## Reduziereinsätze DIN 1835 B für Zylinderschäfte DIN 1835 B+E

Reducing bushes DIN 1835 B for tool shanks DIN 1835 B+E

Réductions DIN 1835 B pour queues cylindriques DIN 1835 B+E



### Verwendung:

Zum Spannen von zylindrischen Werkzeugschäften nach DIN 1835 Form B+E.

### Application:

For mounting straight-shank tools according to DIN 1835 form B+E.

### Application:

Pour le serrage d'outils avec queue cylindrique suivant DIN 1835 forme B+E.

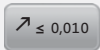
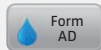
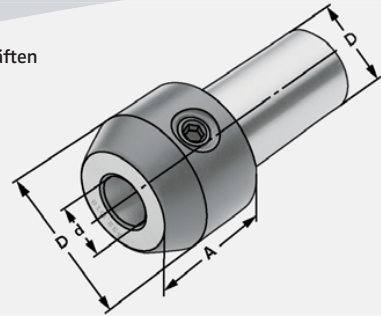

Bestell-Nr.  
Order no.  
Référence

$D_{h6}$

$d_{H4}$

$D_1$

A

122.20.06

20

6

25

30

122.20.08

20

8

28

30

122.20.10

20

10

35

30

122.20.12

20

12

42

35

122.32.06

32

6

25

30

122.32.08

32

8

28

30

122.32.10

32

10

35

30

122.32.12

32

12

42

35

122.32.14

32

14

44

35

122.32.16

32

16

48

38

122.32.18

32

18

50

38

122.32.20

32

20

52

40

### Lieferumfang:

Mit Spanschraube

### Delivery:

With clamping screw

### Livraison:

Avec vis de serrage

