

Guida rapida per la scelta della morsa MULTIFLEX più adatta alle vostre esigenze

Tipo (grandezza) morsa / Vise type (size)

Art. 600

Art. 600S

Ogni morsa è completa di
1 ganaschia fissa, 4 ganasce fisse-mobili
1 chiave a T, 2 tasselli di posizionamento
e 4 arresti laterali

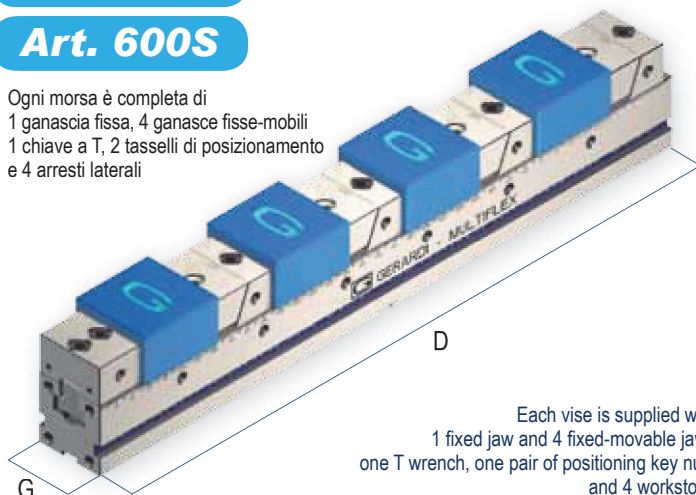

Each vise is supplied with
1 fixed jaw and 4 fixed-movable jaws
one T wrench, one pair of positioning key nuts
and 4 workstops

Apertura max in relazione al numero dei pezzi

Max opening according to pieces to be clamped

kN	1 20 kN		
	300	400	500
D	300	400	500
$G^{-0,02}$	50	50	50
1 pezzo / piece	205	305	408
2 pezzi / pieces	75	125	175
3 pezzi / pieces	30	64	96
4 pezzi / pieces	8	33	58
5 pezzi / pieces	-	15	35
6 pezzi / pieces	-	3	19
7 pezzi / pieces	-	-	8
8 pezzi / pieces	-	-	-
9 pezzi / pieces	-	-	-
10 pezzi / pieces	-	-	-
11 pezzi / pieces	-	-	-
12 pezzi / pieces	-	-	-
Cod. Art. 600	6.60.01300	6.60.01400	6.60.01500
Cod. Art. 600S	6.60.0S130	6.60.0S140	6.60.0S150

Art. 606

Ogni morsa è completa di
1 ganaschia fissa, 4 ganasce fisse-mobili
1 chiave a T, 2 tasselli di posizionamento
e 4 arresti laterali

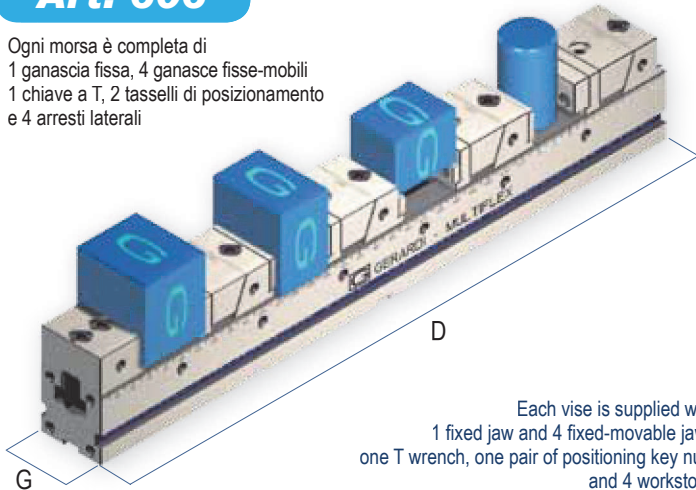

Each vise is supplied with
1 fixed jaw and 4 fixed-movable jaws
one T wrench, one pair of positioning key nuts
and 4 workstops

Apertura max in relazione al numero dei pezzi

Max opening according to pieces to be clamped

D	300 *	400	500
	$G^{-0,02}$	50	50
1 pezzo / piece	193	293	393
2 pezzi / pieces	63	113	163
3 pezzi / pieces	19	53	86
4 pezzi / pieces	-	23	48
5 pezzi / pieces	-	-	25
6 pezzi / pieces	-	-	-
7 pezzi / pieces	-	-	-
8 pezzi / pieces	-	-	-
9 pezzi / pieces	-	-	-
10 pezzi / pieces	-	-	-
11 pezzi / pieces	-	-	-
12 pezzi / pieces	-	-	-
Cod.	6.60.61300	6.60.61400	6.60.61500

* Solo tipo 1 x 300 e 2 x 400 n. 3 ganasce fisse-mobili in dotazione
Only type 1 x 300 and 2 x 400 n. 3 fixed-movable jaws included

Art. 611

Ogni morsa è completa di
3 ganasce fisse, 2 ganasce mobili di spinta
1 chiave a T, 2 tasselli di posizionamento
e 4 arresti laterali

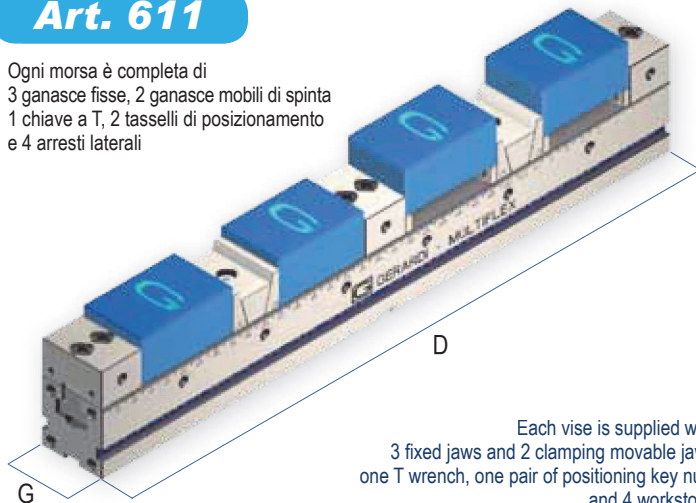

Each vise is supplied with
3 fixed jaws and 2 clamping movable jaws
one T wrench, one pair of positioning key nuts
and 4 workstops

Apertura max in relazione al numero dei pezzi

Max opening according to pieces to be clamped

D	300	400	500
	$G^{-0,02}$	50	50
1 pezzo / piece	174	274	374
2 pezzi / pieces	87	137	185
3 pezzi / pieces	28	62	95
4 pezzi / pieces	21	46	71
5 pezzi / pieces	-	19	39
6 pezzi / pieces	-	16	33
7 pezzi / pieces	-	-	15
8 pezzi / pieces	-	-	13
9 pezzi / pieces	-	-	2
10 pezzi / pieces	-	-	-
11 pezzi / pieces	-	-	-
12 pezzi / pieces	-	-	-
Cod.	6.61.11300	6.61.11400	6.61.11500

Quick guide for the proper MULTIFLEX vise choice according to your specific application

1 20 kN		2 25 kN						3 50 kN			
600	700	400	500	600	700	800	900	700	800	900	1000
50	50	75	75	75	75	75	75	100	100	100	100
508	608	275	375	475	575	675	755	532	632	732	832
225	275	100	150	200	250	300	350	217	267	317	367
129	161	41	75	108	141	175	280	112	145	178	211
83	108	12	37	62	87	112	137,5	59	84	109	134
55	75	-	15	35	55	75	95	28	48	68	88
36	52	-	-	16	33	50	66,5	7	23	39	55
22	36	-	-	3	17	32	46	-	6	2	34
12	24	-	-	-	6	18	31	-	-	5	18
5	16	-	-	-	-	8	19	-	-	-	5
-	8	-	-	-	-	-	10	-	-	-	-
-	2	-	-	-	-	-	2	-	-	-	-
-	-	-	-	-	-	-	-	-	-	-	-
6.60.01600	6.60.01700	6.60.02400	6.60.02500	6.60.02600	6.60.02700	6.60.02800	6.60.02900	6.60.03700	6.60.03800	6.60.03900	6.60.03100
6.60.0S160	6.60.0S170	6.60.0S240	6.60.0S250	6.60.0S260	6.60.0S270	6.60.0S280	6.60.0S290	6.60.0S370	6.60.0S380	6.60.0S390	6.60.0S310

600	700	400 *	500	600	700	800	900	700	800	900	1000
50	50	75	75	75	75	75	75	100	100	100	100
493	593	262	362	462	562	662	762	512	612	712	812
213	263	87	137	187	237	287	337	197	247	294	347
119	152	28	62	95	128	162	195	92	125	158	191
73	97	-	24	49	74	99	124,5	39	64	89	114
45	64	-	2	22	42	62	82	8	28	48	68
26	42	-	-	3	20	37	53,5	-	3	20	37
13	26	-	-	-	4	19	33	-	-	-	14
-	14	-	-	-	-	5	18	-	-	-	-
-	5	-	-	-	-	-	6	-	-	-	-
-	-	-	-	-	-	-	-	-	-	-	-
-	-	-	-	-	-	-	-	-	-	-	-
-	-	-	-	-	-	-	-	-	-	-	-
6.60.61600	6.60.61700	6.60.62400	6.60.62500	6.60.62600	6.60.62700	6.60.62800	6.60.62900	6.60.63700	6.60.63800	6.60.63900	6.60.63100

600	700	400	500	600	700	800	900	700	800	900	1000
50	50	75	75	75	75	75	75	100	100	100	100
474	574	242	342	442	542	642	792	470	570	670	770
237	287	121	171	221	271	321	371	235	285	335	285
128	162	45	78	112	145	178	228	103	136	169	202
96	121	34	59	84	109	134	158,5	77	102	127	152
59	79	5	25	45	65	85	115	30	50	70	90
49	66	-	21	38	54	71	87,5	25	41	57	73
30	44	-	3	17	31	46	66,5	-	12	26	40
26	38	-	-	15	27	40	52	-	11	23	35
13	24	-	-	1	12	23	40	-	-	3	14
12	22	-	-	-	11	21	31	-	-	-	-
3	12	-	-	-	-	10	22,5	-	-	-	-
2	11	-	-	-	-	9	16,5	-	-	-	-
6.61.11600	6.61.11700	6.61.12400	6.61.12500	6.61.12600	6.61.12700	6.61.12800	6.61.12900	6.61.13700	6.61.13800	6.61.13900	6.61.13100

Tipo (grandezza) morsa / Vise type (size)

Art. 600

Morsa con ganasce lisce (Art. 605) / Vise with smooth jaws (Art. 605)

Art. 600S

Morsa con ganasce zigrinate (Art. 605S) / Vise with serrated jaws (Art. 605S)

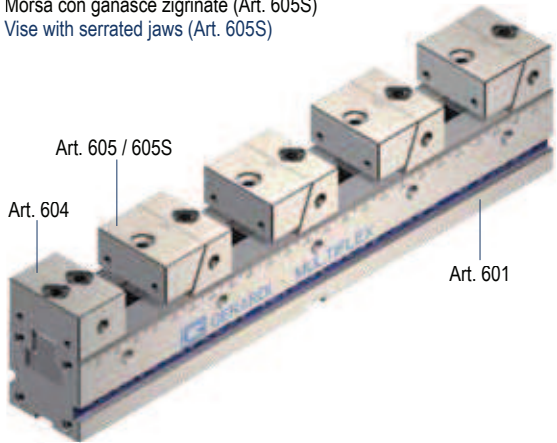

kN	1				
	20 kN				
A	4 x 8mm	4 x 33	4 x 58	4 x 83	4 x 108
B	32 / 25				
C $^{0}_{-0,02}$	50				
D	300	400	500	600	700
G $^{0}_{-0,02}$	50				
J	38				
J1	55 / 58				
I	10				
L	15				
Z	100				
W	49				
Ø P	9				
Q	100	100	300	300	400
Ø F7	10				
kg	7,2	8,7	10,1	11,6	13
Cod. Art. 600	6.60.01300	6.60.01400	6.60.01500	6.60.01600	6.60.01700
Cod. Art. 600S	6.60.0S130	6.60.0S140	6.60.0S150	6.60.0S160	6.60.0S170



AMPLIA LE TUE APPLICAZIONI TRAMITE GLI ACCESSORI MODULARI !

Art. 604

Ganascia fissa / Fixed jaw

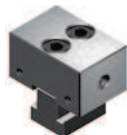

Cod. 6.60.41000

Art. 605

Ganascia mobile e fissa liscia / Fixed and movable smooth jaws



Art. 605S

Ganascia mobile e fissa zigrinata / Fixed and movable serrated jaws



Cod. Art.605 6.60.51000

Cod. Art.605S 6.60.5S100

Art. 605L

Cuneo di spinta a "V" / "V" clamping wedge



Cod. 6.60.5L100

Art. 615

Ganascia con cuneo di posizionamento maggiorato / Jaw with bigger positioning wedge (increased with respect to standard dimensions)

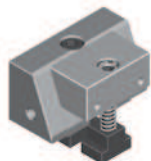

Cod. 6.61.51000

Art. 600 / Art. 600S

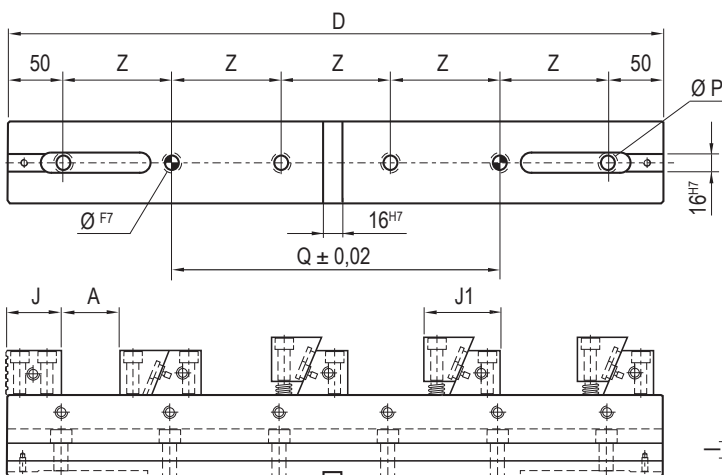

Ogni morsa è completa di 1 ganascia fissa, 4 ganasce fisse-mobili / 1 chiave a T, 2 tasselli di posizionamento e 4 arresti laterali
Each vise is supplied with 1 fixed jaw and 4 fixed-movable jaws / 1 T wrench, one pair of positioning key nuts and 4 workstops

Ø = Sede viti calibrate / Hole for calibrated screw

Art.81	Tipo - Type 1	Ø10h7 x 25
Art.81	Tipo - Type 2	Ø16h7 x 40
Art.81	Tipo - Type 3	Ø16h7 x 50

Vedi pag. 6.34 - Vedi page 6.34

Art. 600	Art. 600S	Pag.
n° 1 Art. 601		6.26
n° 1 Art. 604		6.28
n° 4 Art. 605	n° 4 Art. 605S	6.29

	2 30 kN						3 40 kN			
	4 x 12mm	4 x 37	4 x 62	4 x 87	4 x 112	4x137	4 x 59	4 x 84	4 x 109	4 x 134
A										
B	40						60			
C ⁻⁰ _{-0,02}	75						100			
D	400	500	600	700	800	900	700	800	900	1000
G ⁻⁰ _{-0,02}	75						100			
J	50						70			
J1	70 / 75						94,5 / 98,5			
I	16						12			
L	20						20			
Z	100						100			
W	74						99			
P	13						17			
Q	300	200	300	400	500	400	400	500	400	500
Ø F7	16						16			
kg	22,45	25,95	29,45	32,95	36,4	39,9	65,1	70,6	77,6	83,3
Cod. Art. 600	6.60.02400	6.60.02500	6.60.02600	6.60.02700	6.60.02800	6.60.02900	6.60.03700	6.60.03800	6.60.03900	6.60.03100
Cod. Art. 600S	6.60.0S240	6.60.0S250	6.60.0S260	6.60.0S270	6.60.0S280	6.60.0S290	6.60.0S370	6.60.0S380	6.60.0S390	6.60.0S310

UPGRADE YOUR VISE APPLICATIONS THROUGH MODULAR ACCESSORIES !

Cod.	6.60.42000	6.60.43000
------	------------	------------

Cod. Art.605	6.60.52000	6.60.53000
Cod. Art.605S	6.60.5S200	6.60.5S300

Cod.	6.60.5L200	6.60.5L300
------	------------	------------

Cod.	6.61.52000	6.61.53000
------	------------	------------

Art. 605

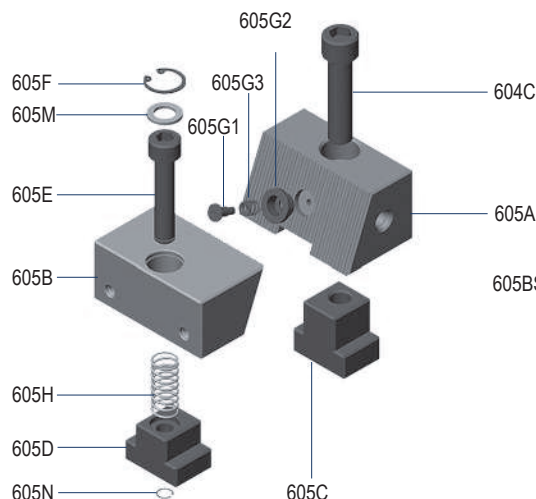

Art. 605S

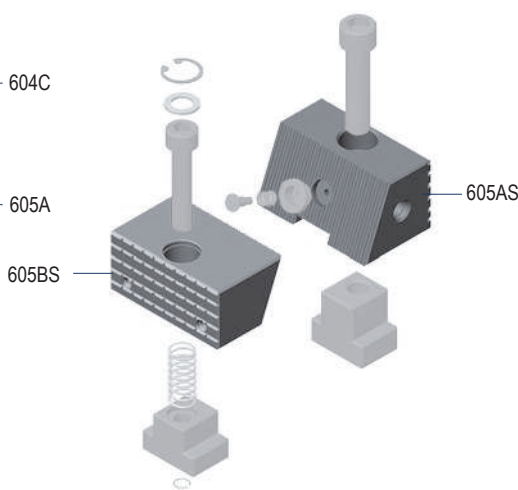

Art. Pag.

605A	
605AS	
605B	
605BS	
604C	
605C	
605D	
605E	6.31
605F	
605G1	
605G2	
605G3	
605H	
605M	
605N	

SERRAGGIO MECCANICO CON CHIAVE DINAMOMETRICA

MECHANICAL CLAMPING WITH TORQUE WRENCH

I diagrammi seguenti consentono di determinare le forze di serraggio ottenibili con le morse di varia grandezza (da 1 a 3), in funzione della forza applicata

The following diagrams give the clamping force that can be obtained with each vise type (size 1 to 3) as a function of wrenching force

MORSE MULTIFLEX TIPO 1
MULTIFLEX VISES TYPE 1

Ganascia fissa e cuneo di posizionamento:
Momento applicato 40Nm
 Fixed jaw and positioning Wedge: **Torque 40Nm**

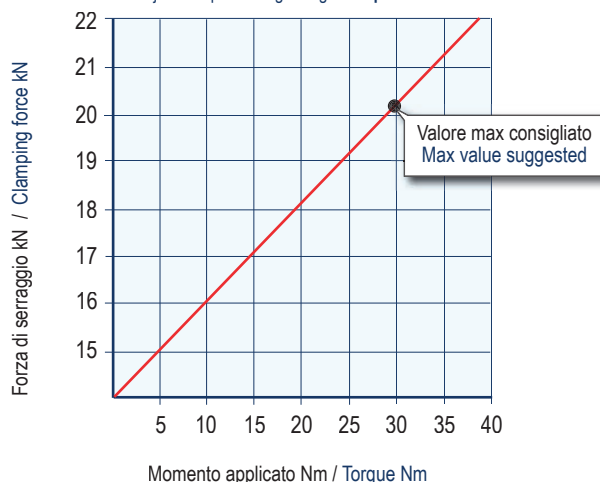

MORSE MULTIFLEX TIPO 2
MULTIFLEX VISES TYPE 2

Ganascia fissa e cuneo di posizionamento:
Momento applicato 120Nm
 Fixed jaw and positioning Wedge: **Torque 120Nm**

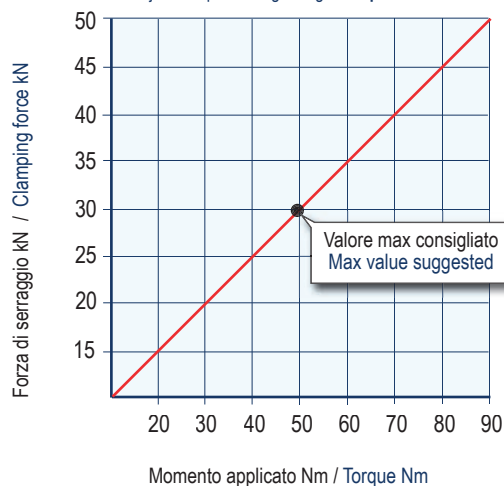

MORSE MULTIFLEX TIPO 3
MULTIFLEX VISES TYPE 3

Ganascia fissa e cuneo di posizionamento:
Momento applicato 250Nm
 Fixed jaw and positioning Wedge: **Torque 250Nm**

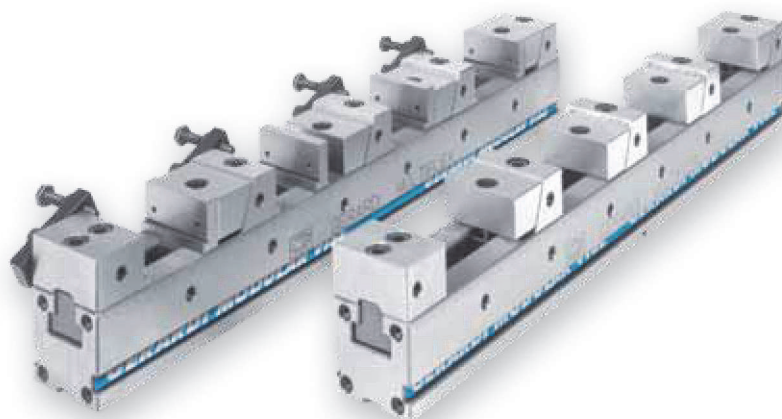
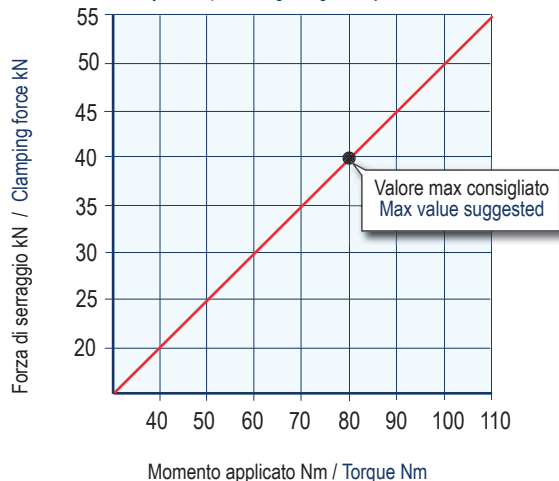

NB: Alcuni fattori, come la lubrificazione, lo staffaggio, gli attriti ed altro, possono modificare i valori indicati fino a $\pm 10\%$. Per un corretto utilizzo non superare i valori indicati nel grafico

Some factor as lubrication, clamping on the machine table, frictions and more can modify above values within a $\pm 10\%$ range. For optimum operation do not exceed chart values.