

CUBI A CROCE CROSS CUBES

Art. 57E

Reticolo integrale
Grid cube

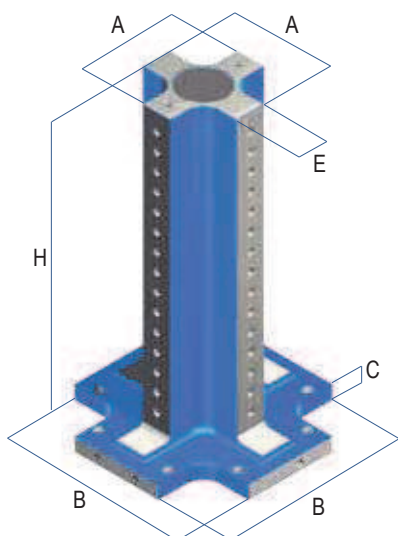

Art. 57F

Reticolo con bussole
Grid cube
with bushing

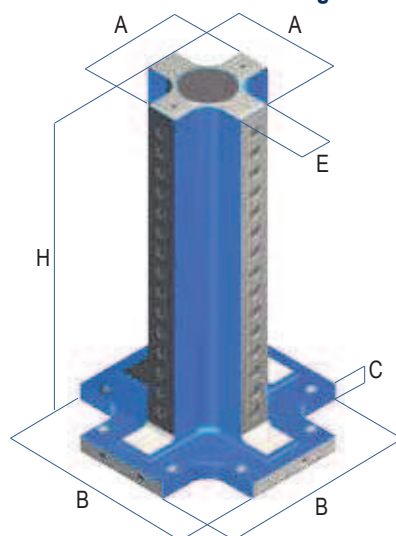

Stesse dimensioni dell'Art. 57C / Same dimensions of Art. 57C
Peso: -5% circa rispetto Art. 57C / Weight: About -5% of Art. 57C

Specifiche Specifications

Art. 57A

Fusione in ghisa G30 monoblocco sgrassata con doppio trattamento di distensione.
Pareti con spessore 43-45 mm
(Sovrametallo 10 mm)

One integral G30 cast iron casting rough milled with double stress relieving heat treatment.
Wall thickness 43-45 mm
(10 mm stock)

Art. 57B

Fusione sgrassata con base lavorata e raschiata per pallet a norme Europee o Giapponesi.

Vedi specifiche a pag. 8.4

Rough milled casting with base face machined and hand scraped for direct clamping on European or Japanese standard pallet.

See specifications pag. 8.4

Art. 57C

Cubo a croce completamente finito con pareti spessore 38-40 mm circa.

Crosscube completely finished with wall thickness roughly 38-40 mm

Art. 57E 40 / 50

Cubo a croce a reticolo con fori calibrati e filettati integrali - Tolleranza $\pm 0,02$ mm

■ Interasse reticolo 40 mm = $\varnothing 12$ / M10

■ Interasse reticolo 50 mm = $\varnothing 16$ / M12

Cross cube with calibrated holes and solid threads - Tolerance $\pm 0,02$ mm

■ Grid pitch 40 mm = $\varnothing 12$ / M10

■ Grid pitch 50 mm = $\varnothing 16$ / M12

Art. 57F 40 / 50

Cubo a croce a reticolo con bussole temprate 100Cr6 e filetti riportati in acciaio inox
Tolleranza $\pm 0,02$ mm

■ Interasse reticolo 40 mm = $\varnothing 12$ / M10

■ Interasse reticolo 50 mm = $\varnothing 16$ / M12

Grid cross cube with hardened bushing 100Cr6 and stainless steel helicoils
Tolerance $\pm 0,02$ mm

■ Grid pitch 40 mm = $\varnothing 12$ / M10

■ Grid pitch 50 mm = $\varnothing 16$ / M12

Art. 57E 40		Art. 57E 50		Art. 57F 40		Art. 57F 50	
Cod.		Cod.		Cod.		Cod.	
8.57.E40100		8.57.E00100		8.57.F40100		8.57.F00100	
8.57.E40105		8.57.E00105		8.57.F40105		8.57.F00105	
8.57.E40106		8.57.E00106		8.57.F40106		8.57.F00106	
8.57.E40110		8.57.E00110		8.57.F40110		8.57.F00110	

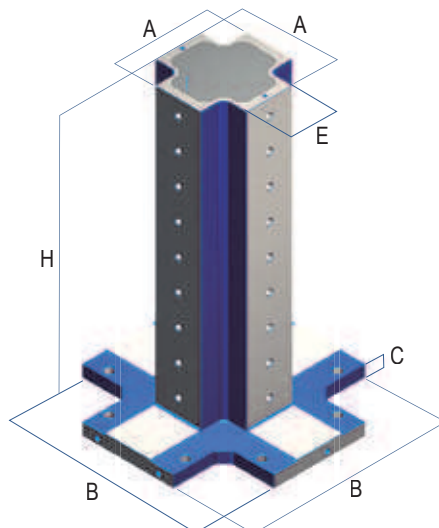
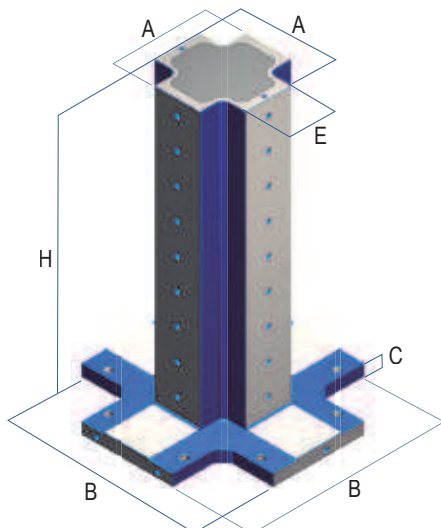

8.57.E40120		8.57.E00120		8.57.F40120		8.57.F00120	
8.57.E40130		8.57.E00130		8.57.F40130		8.57.F00130	
8.57.E40140		8.57.E00140		8.57.F40140		8.57.F00140	
8.57.E40145		8.57.E00145		8.57.F40145		8.57.F00145	
8.57.E40150		8.57.E00150		8.57.F40150		8.57.F00150	

► Non sgrassato di fresa - Not rough milled

! For different finishing and materials (aluminium), ask for specific quotation