

MGR Bars Grooving - with Coolant Channel

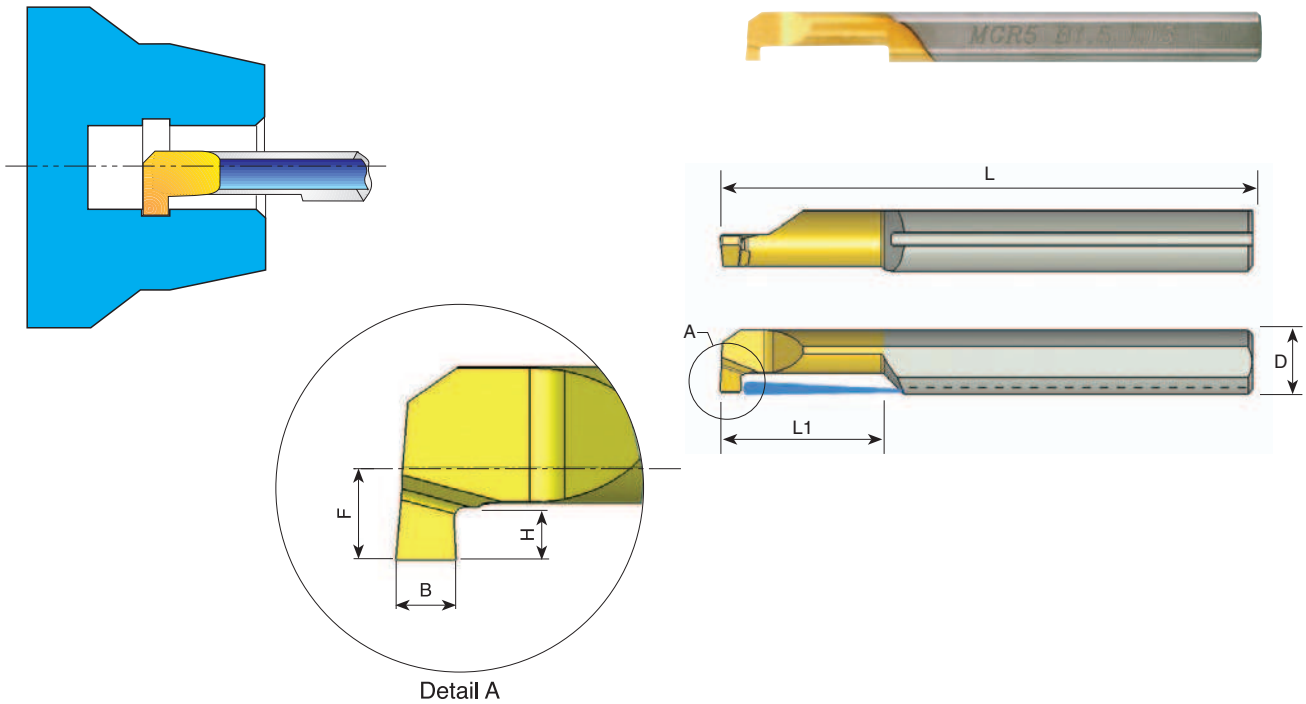

D	Ordering Code	L	L1	B	H	F	Min. Bore Dia.	Holder*
4.0	MGR 4 B1.0 L10	50	10	1.0	1.0	1.7	4.1	SIM 0020 H4
4.0	MGR 4 B1.5 L10	50	10	1.5	1.0	1.7	4.1	SIM 0020 H4
5.0	MGR 5 B1.0 L15	50	15	1.0	1.2	2.3	5.1	SIM 0020 H5
5.0	MGR 5 B1.5 L15	50	15	1.5	1.2	2.3	5.1	SIM 0020 H5
5.0	MGR 5 B2.0 L15	50	15	2.0	1.2	2.3	5.1	SIM 0020 H5
6.0	MGR 6 B1.0 L15	50	15	1.0	1.4	2.8	6.1	SIM 0020 H6
6.0	MGR 6 B1.5 L15	50	15	1.5	1.4	2.8	6.1	SIM 0020 H6
6.0	MGR 6 B2.0 L15	50	15	2.0	1.4	2.8	6.1	SIM 0020 H6

Order example: MGR 5 B1.5 L15 BXC

For L.H. bars specify MGL instead of MGR

* For additional holders see page 156

Technical Section

Carbide Grade: **BXC (P30 - P50, K25 - K40)**

PVD TiN coated grade for low cutting speed, Works well with a wide range of stainless steels.

Cutting speed for Tiny Tools

ISO Standard	Materials	Cutting Speed m/min
P	Low & Medium Carbon Steel	20-140
	High Carbon Steel	30-100
	Alloy Steels & Treated Steels	40- 90
M	Stainless Steels	20- 90
	Cast Steels	40- 90
K	Cast Iron	40-120
N	Non-Ferrous & Aluminium	50-120
S	Super alloy and Titanium	15- 30
H	Hard Materials	13- 30

Recommended Feed Rate: 0.01 - 0.03 mm/rev

Threading Passes

Pitch:	mm	0.5	0.7	0.8	1.0	1.25	1.5
	TPI	48	36	32	24	20	16
Number of Passes		6-12	7-14	7-16	8-18	8-20	10-22